

PART NO.
20367-001R

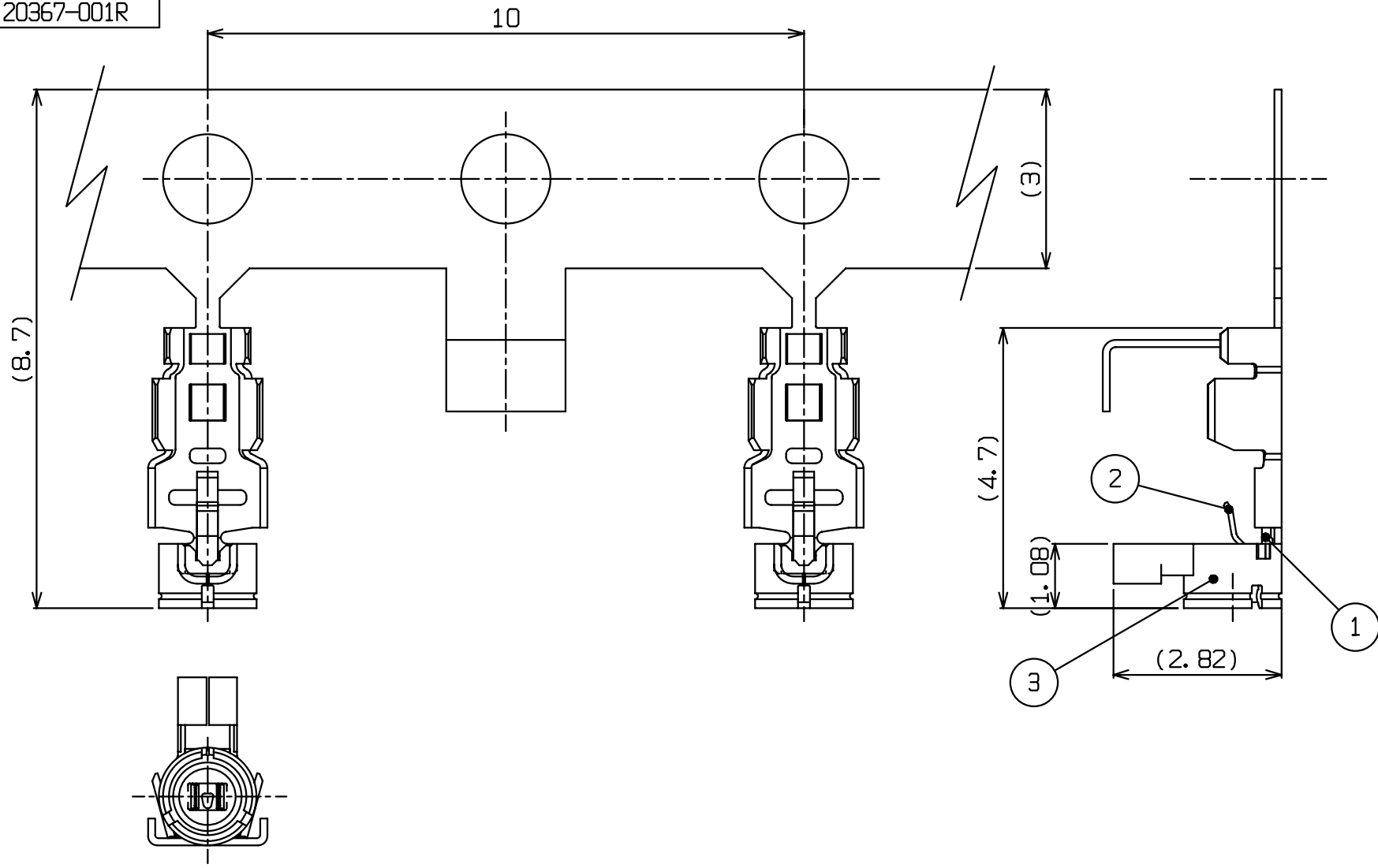

NOTES

1. MATERIAL
 - ① HOUSING : LCP (Natural) UL94-V0
 - ② CONTACT : Phosphor Bronze Au Over Ni
 - ③ GROUND CONTACT : Phosphor Bronze Au Over Ni
2. PACKING : REEL
3. APPLICABLE CABLE
 - 3-1. DESCRIPTION
 - Inner conductor : AWG#36(7/0.05)
 - Silver plating annealed copper wire or silver plating tin-copper alloy.
 - Must not use solder coated inner conductor.
 - Dielectric core: Fluoro-plastics, diameter $0.4(+0.04/-0.02)$ mm, nominal thickness 0.125 m.
 - Outer conductor: 8/5/0.05, nominal diameter 0.65 mm, silver plating annealed copper wire.
 - Must not use solder coated outer conductor.
 - Jacket : Fluoro-plastics, diameter $0.81(+0.04/-0.02)$ mm, nominal thickness 0.08 mm.
 - 3-2. REQUIREMENTS
 - Characteristic impedance : $50(+2/-2)$ ohm by TDR method
 - Nominal capacitance(Reference value) : 96 pF/m
 - Conductor resistance of inner conductor at 293K (Reference value): 1400 ohm/km
 - Insulation resistance : 1000 mega-ohm.km MIN.
 - Dielectric withstance voltage : no breakdown at AC1000V for 1 minutes.

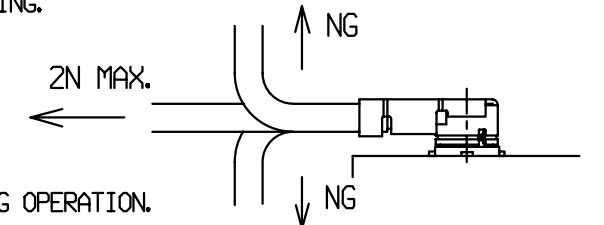

4. PERMISSIBLE LOAD OF CABLE AT MATING.

5. SUGGESTIONS FOR MATING & UNMATING OPERATION.
5-1. MATING
Please mate the connector straightly to vertical direction as much as possible, adjusting the mating axis of plug and receptacle. As excessive slant angle mating may break the connector, please don't do it.

5-2. UNMATING
5-2-1.
In case of unmating by pulling tool.
Please use the pulling tool as the following drawing, and please pull plug to vertical direction as directly as possible.

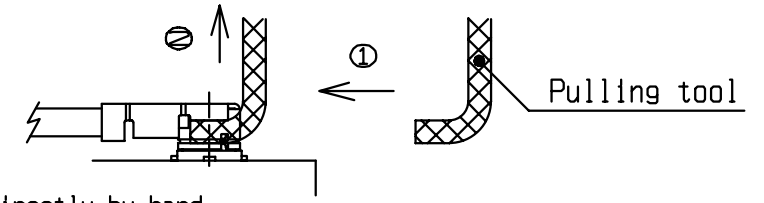

5-2-2.
In case of unmating directly by hand.
Please catch the catching area of plug, and please pull plug to vertical direction as directly as possible.

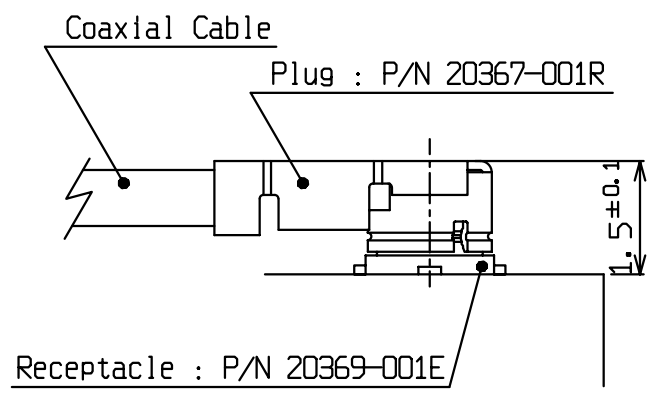
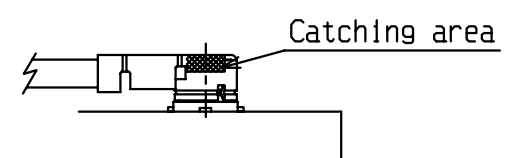

MATING

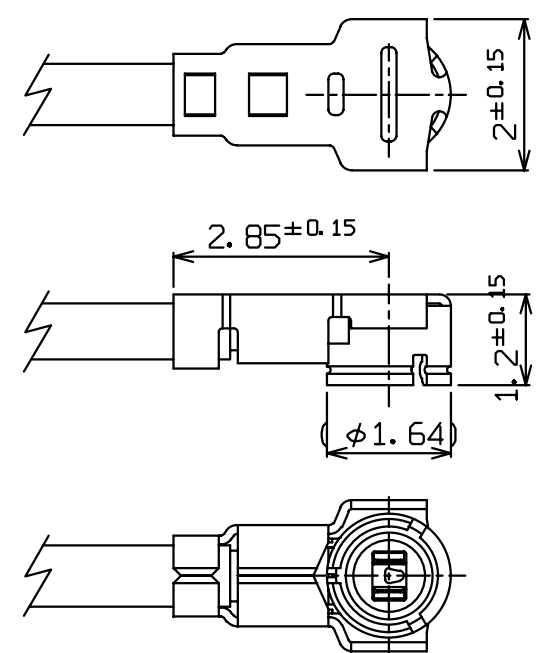

ASSEMBLY

GENERAL TOLERANCE	
6 MAX.	±0.2
6 OVER MAX. 30	±0.3
30 OVER MAX. 120	±0.5
ANGLE	±2°

DESIGN'D BY	DATE	I-PEX Interconnect and Packaging Electronics TOKYO, JAPAN
T. TAKANO	Mar./01/04	
CHK'D BY	DATE	TITLE
T. HARADA	Mar./02/04	
APP'D BY	DATE	MHF III Connector Plug
K. KATABUCHI	Mar./02/04	
REV. RECORD	CUSTOMER COPY	PROJECTION
SERIES No.	SCALE	UNIT
	10/1	mm
	DWG. No.	SHEET
	20367	1/2
		REV.
		2

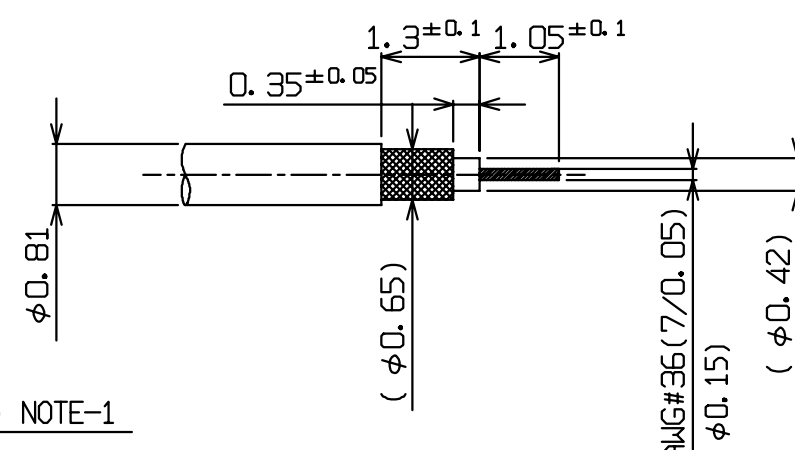
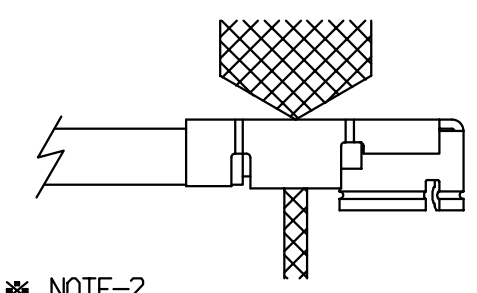
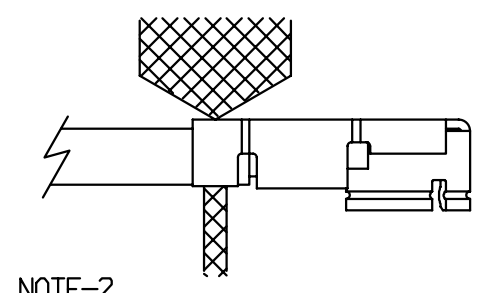
Part No.	20367-001R	
Applicable cable nominal dimension	 <p>※ NOTE-1</p>	
Braided shield of Outer conductor 外部導体の編組	Single / 1重編組	
P/N of semi auto termination machine	90283-008 Semi-auto	
Crimp Height	 <p>※ NOTE-2</p> <p>CH-1(Inner conductor) 0.89 ~ 0.93</p>	 <p>※ NOTE-2</p> <p>CH-2(Jacket part) 0.80 ~ 0.85</p>

NOTES

1. 中心導体、外部導体への半田コーティングは不可。
Must not use solder coated inner conductor and outer conductor.
2. ポイントマイクロメータを使用。
Use for point micrometer.

DESIGN' D BY	DATE	 I-PEX Interconnect and Packaging Electronics TOKYO, JAPAN	TITLE		SHEET	REV.
CHK' D BY	DATE		MHF III Connector Plug			
APP' D BY	DATE		SCALE	UNIT		
CUSTOMER COPY	PROJECTION	10/1	mm	20367	2/2	2